

**GainSpan**  
**GS1011**

**Ultra Low-Power Wireless System on Chip (SoC)**



**PRODUCT OVERVIEW**

GS1011 device is a highly integrated ultra low power wireless single chip which contains an 802.11 radio, media access controller (MAC) and baseband processor, on-chip flash memory and SRAM, and an applications processor all on a single package. The GS1011 supports the full 802.11b (11Mbps) data rates providing scalability on data throughput for higher bandwidth application while still providing the ultra low power consumption for years of battery life. Along with its embedded software stack it offers a highly scalable, reliable, manageable and secure wireless link to meet the growing demand of wireless sensor networks utilizing the broadly accepted IEEE 802.11 standards infrastructure. This solution is ideal for use in smart energy, building automation, industrial and commercial automation and cold storage monitoring applications. In addition, the solution provides capabilities such as location awareness which also make it well suited for logistics and supply chain applications for tracking asset location and status.

**FEATURES & BENEFITS**

- **Highly Integrated wireless SOC with 802.11 radio, MAC and Baseband, Integrated PA, Application CPU, RTC, SRAM and FLASH**
  - Reduces system cost of implementing separate devices and lowers design complexity
  - Ultra small form-factor reduces board space
- **Supports IEEE 802.11**
  - Lowers customer’s total cost of ownership (TCO) in network implementation and management
  - Seamlessly integrates with existing 802.11b/g infrastructure and utilizes the 802.11 security, manageability, ease-of-use, and quality of service
  - Supports full 802.11b data rates (up to 11 Mbps) for higher bandwidth applications

- **802.11i/WPA2 Authentication, AES Hardware encryption**
  - Enterprise level security & reliability for sensor networks
- **Power Management**
  - Optimized for battery powered application with very low power consumption for multiple years of battery life
- **Location Awareness**
  - Enables users to trace and monitor assets
- **Multiple I/O: SPI, UART, PWM, I2C, ADC, GPIO**
  - Provides flexibility in system design for easier integration
- **Firmware, Device drivers, Reference Application SW, APIs, and SDK**
  - Reduces customer development time for application software enabling faster time to market

**GS1011 BLOCK DIAGRAM**

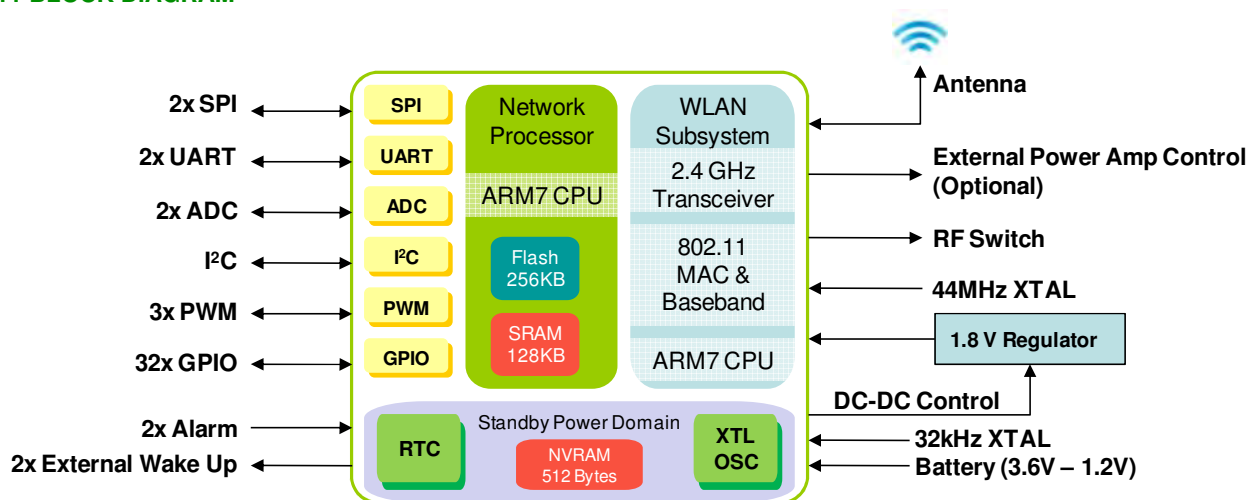

**GS1011 SoC REFERENCE SPECIFICATIONS**

<b>Dual-Core Processors</b>	Two 32-bit ARM7 CPU @44MHz 1 for Networking Services : 1 for 802.11 radio (WLAN)
<b>On Board Memory</b>	RAM 128KBytes FLASH 384KBytes ROM 80KBytes
<b>Radio (Wi-Fi)</b>	802.11b ( 802.11b/g/n compatible) Rates Supported: 11, 5.5, 2 and 1 Mbps (CCK/QPSK/BPSK Modulation)
<b>Security</b>	WEP, WPA/WPA2 Personal, WPA/WPA2 Enterprise RC4, AES Encryption
<b>RF Power (Typical)</b>	8 dBm (internal PA)
<b>Range</b>	50-70M Indoor : 200-300M+ Outdoor (Typical Estimate)
<b>Operating Temp Range</b>	-40 to +85 °C industrial temp
<b>Location Awareness</b>	RSSI
<b>Firmware Protocol Support</b>	TCP/IP, UDP, HTTP, SNMP, DNS, DHCP, SSL etc.
<b>Standby State with RTC*</b>	1- 5uA depends on voltage on RTC
<b>Package</b>	10 x 10 x 0.85 mm; 102-pin dual row QFN; RoHS compliant
<b>I/Os</b>	UART (2), I2C, SPI (2), ADC(2), PWM(3), GPIO(32)

\* Lowest power state

**APPLICATIONS**



• Healthcare



• Smart Energy



• Industrial Control and Monitoring



• Commercial/Building Automation



• Consumer

