

Complete W-LAN module (Type-SN)

■ Stand-alone Complete W-LAN module

- CPU, W-LAN function and stack (TCP/IP, Supplicant) are embedded

■ Serial interface

- Easy to control with simple command

1. Complete W-LAN Module

- Chipset : **GainSpan GS1011**
- Size : **31.0 x 21.4 (mm), h<3.5**
- IEEE802.11b
- Embedded X'tal, DDcon, Antenna, BtoB Connctor
- Interface : UART (SPI, I2C),ADC,GPIO,PWM
- Lead Free Module

2.Characteristics

- Operating Temperature : -20 to +70 deg.C
- Supply Voltage : 3.3V
- Host I/F Voltage : 1.8V or 3.3V
- Output Power : +15.0dBm typ.
- Power Consumption :
 - Tx mode(9dBm) 350mA
 - Rx 164mA
 - Standby mode 5μA

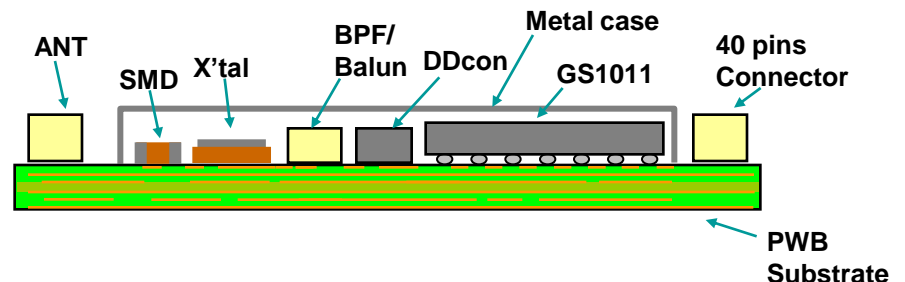
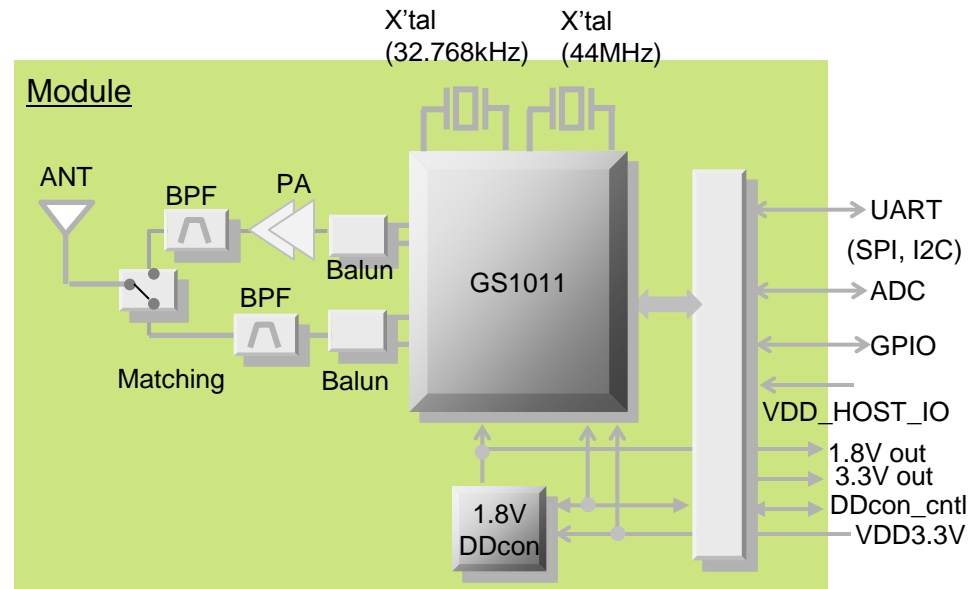

Murata contact windows



- <Japan> Katsunari Nakanishi : [Murata Manufacturing Co.,Ltd. <Head office>](#)
Phone: +81-(0)75-955-6807
E-mail: katsunari_nakanishi@murata.co.jp
- <USA> Mehul Udani : [Murata Electronics North America,Inc.](#)
Phone: 972-248-2898
E-mail: modules@murata.com
- <Europe> Mac Tochigi : [Murata Electronics Europe B.V.](#)
Phone: +31-(0)23-56-98-468
E-mail: mtochigi@murata.nl
Rui Ramalho
Phone: +31-(0)23-56-98-414
E-mail: rramalho@murata.nl
- <China> Kenichi Shibano : [Murata Electronics Trading\(Shanghai\) Co.,Ltd.](#)
Phone: +86-(0)21-3205-4616
E-mail: shibano@sh-murata.com.cn
- <Korea> Takayuki Shinozaki: [Korea Murata Electronics Co.,Ltd.](#)
Phone: +82-(0)2-3016-3393
E-mail: tshino@murata.co.jp
- <Taiwan> Yuya Sakai : [Murata Taiwan Electronics Co.,Ltd.](#)
Phone: +886-2-5573-9307
E-mail: Yuya.Sakai@mail.murata.com.tw